

003 18 57

FRONT CONTACT ADAPTERS FOR SCREW IN-TOOLS

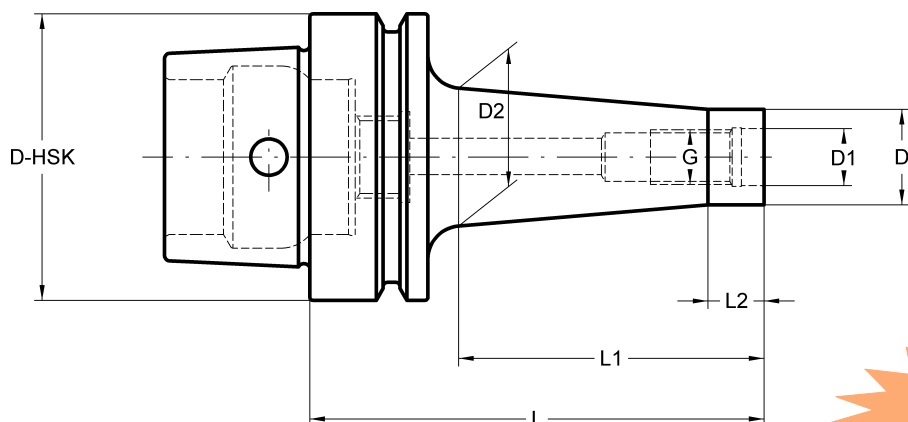

Runout between K and D₁ ≤ 0,005

D HSK-E	G	D	D ₁	D ₂	L	L ₁	L ₂	COD.	€
40	M-6	9,8	6,5	10	50	25	10	003 18 57 12 01	
40	M-6	9,8	6,5	24	100	75	10	003 18 57 32 01	
40	M-8	12,8	8,5	16	50	25	10	003 18 57 12 02	
40	M-8	12,8	8,5	24	100	75	10	003 18 57 32 02	
50	M-8	12,8	8,5	16	55	25	10	003 18 57 13 02	
50	M-8	12,8	8,5	24	105	75	10	003 18 57 33 02	
50	M-10	17,8	10,5	20	55	25	10	003 18 57 13 03	
50	M-10	17,8	10,5	28	105	75	10	003 18 57 33 03	

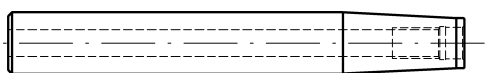

Cylindrical extensions

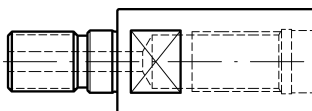

Extensions

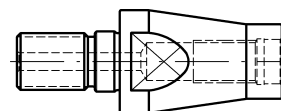

Reducers

Delivery:

- Balanced according to ISO 1940-1 up to 15.000 R.p.m.
- We have latest methods for dynamic balancing up to 50.000 R.p.m.
- Coolant tube to be ordered separately.