

019 14 52 ...

QUICK-CHANGE TAPPING CHUCKS

With self feed and compression system. For BILZ system tap adapter



ALTERNATIVE SOLUTIONS 012 14 ⁰¹/₀₄ + 019 55 52

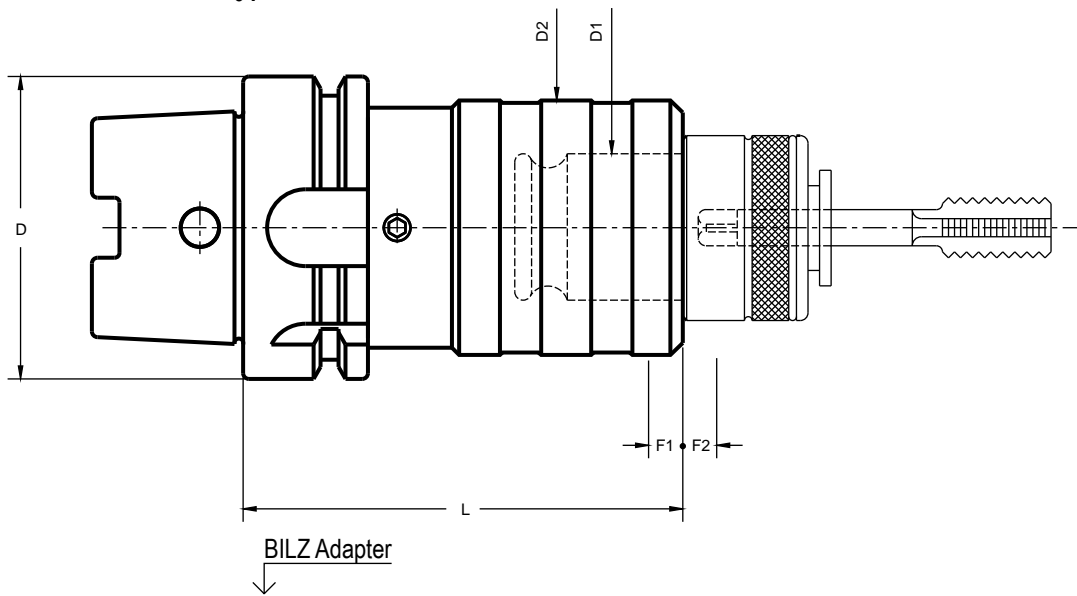

D HSK-A	CAP.	D ₁	L	D ₂	F ₁	F ₂	COD.	€
50	M3-M12 (M-16)*	19	116	36	7,5	7,5	019 14 52 03 02	
63	M3-M12 (M-16)*	19	112	36	7,5	7,5	019 14 52 04 02	
63	M8-M20 (M-30)*	31	145	53	12,5	12,5	019 14 52 04 03	
80	M3-M12 (M-16)*	19	115	36	7,5	7,5	019 14 52 05 02	
80	M8-M20 (M-30)*	31	145	53	12,5	12,5	019 14 52 05 03	
100	M3-M12 (M-16)*	19	130	36	7,5	7,5	019 14 52 06 02	
100	M8-M20 (M-30)*	31	153	53	12,5	12,5	019 14 52 06 03	
100	M14-M33 (M-48)*	48	215	78	20	20	019 14 52 06 04	

F₁ Compression run

F₂ Extension run

* With 002 22 ... and 002 24 ... adapters

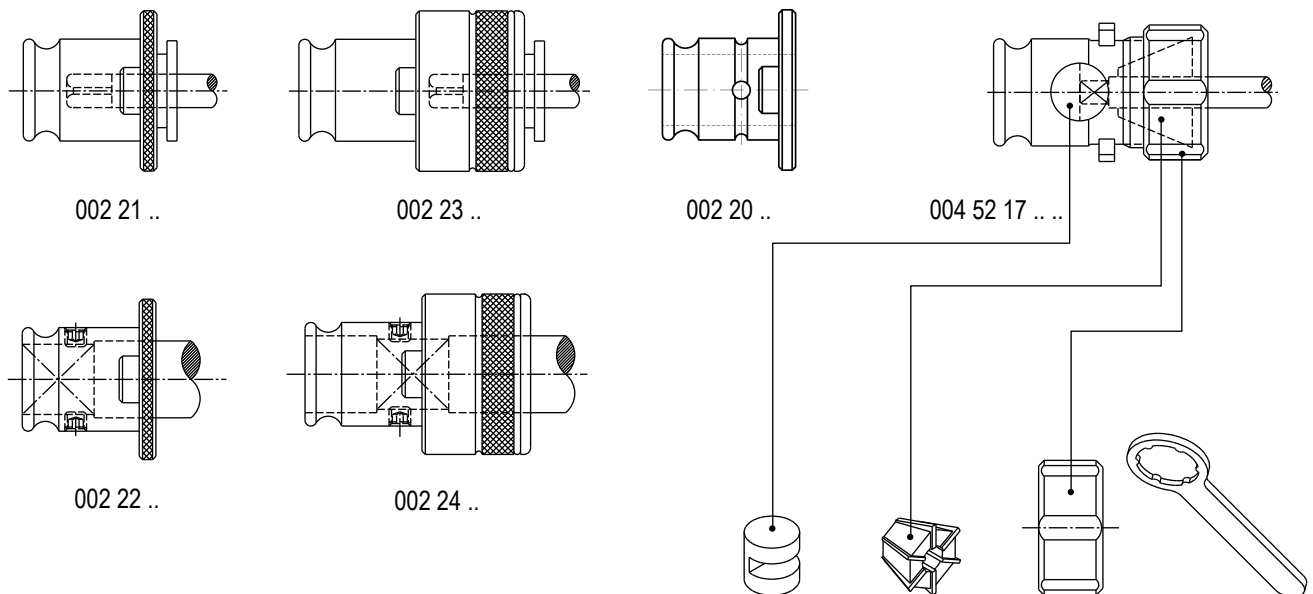

D₁

19	002 21 02	002 22 02	002 23 02	002 24 02	004 52 17 02 02	(M3 - M12)	019 99 52 00 00	002 17 02 ...	004 99 01 09 02	OPTIONAL
31	002 21 03	002 22 03	002 23 03	002 24 03	004 52 17 03 03	(M8 - M16)	019 99 53 00 00	002 17 03 ...	004 99 01 09 03	004 99 04 04 03
48	002 21 04	002 22 04	002 23 04	002 24 04	-	-	-	-	-	-