

# 003 14 11 .. ..

## REDUCING ADAPTERS

For tapered Morse taper tools DIN 228-B



ALTERNATIVE SOLUTION 003 14 54 + 003 54 12

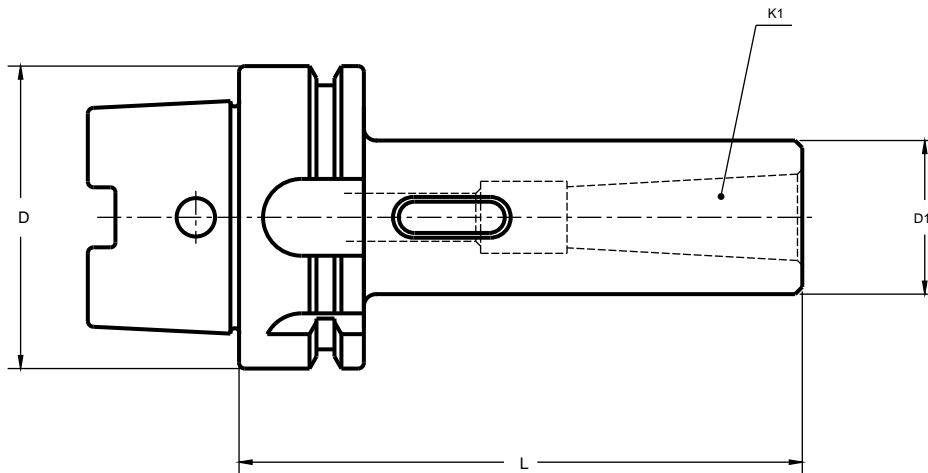

Runout between outer taper and  $K_1 \leq 0,008$

D HSK-A	$K_1$	L	$D_1$	COD.	€
50	1	100	25	003 14 11 03 21	
50	2	120	32	003 14 11 03 31	
50	3	140	40	003 14 11 03 41	
63	1	100	25	003 14 11 04 21	
63	2	120	32	003 14 11 04 31	
63	3	140	40	003 14 11 04 41	
63	4	160	48	003 14 11 04 51	
80	1	110	25	003 14 11 05 21	
80	2	120	32	003 14 11 05 31	
80	3	140	40	003 14 11 05 41	
80	4	170	48	003 14 11 05 51	
80	5	200	63	003 14 11 05 61	
100	1	110	25	003 14 11 06 21	⚠
100	2	120	32	003 14 11 06 31	
100	3	150	40	003 14 11 06 41	
100	4	170	48	003 14 11 06 51	
100	5	200	63	003 14 11 06 61	

Coolant tube to be ordered separately.

⚠ Product outside of our present production program. Price subject to availability.