

Collet Chucks for ER/ESX ER-11/16 Collets with Internal Thread

similar to DIN 69 882-6

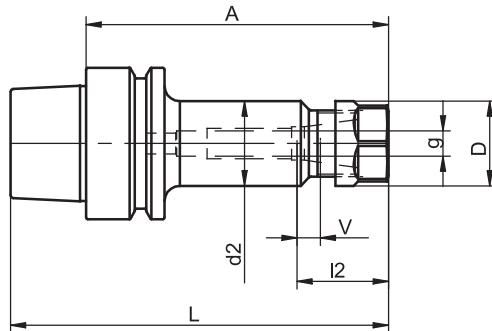

HSK-E	Clamping range	A	Ref.no.	d2	D	l2	g	L	V	kg
40	0.5 - 7	60	698.0011.362	18.5	19	18	M 6	80	5	0.3
40	0.5 - 10	60	698.0001.362	28	32	27	M10	80	5	0.4
50	0.5 - 10	100	698.0001.363	28	32	27	M10	125	10	0.6

For coolant tubes see accessories page 4.8

For adjusting screws see accessories page 4.9

For further accessories such as collets, clamping nuts or clamping keys see accessories from page 4.3 to page 4.7

Use

For clamping tools with straight shank according to DIN 6499 type A and B.

Design

Permissible concentricity deviation of hollow taper shank to inner taper 0.003 mm. Chucks are fine balanced without clamping

nut according to ISO 1940-1 G 6.3 at 12,000 min⁻¹. Clamping nut balanced to G 6.3 at 18,000 min⁻¹.

Standard Specification

Collet chuck including clamping nut.

Note

Collet chucks are equipped with internal thread for adjusting screws. Other designs and sizes are available on request.

TAC Rockford - Tel. 815 962-4500 - info@TACRockford.com - www.TACRockford.com