

Collet Chucks

for ER/ESX ER-25/32 Collets with Internal Thread

DIN 69 882-6

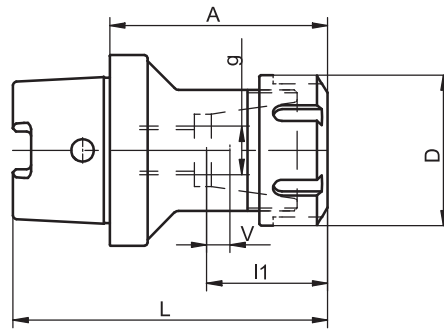

HSK-C	Clamping range	A	Ref.no.	D	I1	g	L	V	kg
63	1 - 16	70	697.0003.343	42	36	M10	102	5	1.1
100	2 - 20	80	697.0001.345	50	40	M16	140	5	2.7

For adjusting screws see accessories page 4.11

For more accessories like collets, clamping nuts or clamping keys see accessories pages 4.3 to 4.7

Use

For clamping tools with straight shank according to DIN 6499 type A and B.

Design

Permissible concentricity deviation of hollow taper shank to inner taper: 0.003 mm.
Chucks are fine balanced without clamping

nut according to ISO 1940-1 G 6.3 at 12,000 min⁻¹.
Clamping nut balanced to G 6.3 at 18,000 min⁻¹.

Standard Specification

Collet chuck including clamping nut.

Note

Collet chucks are equipped with internal thread for adjusting screws.
Other designs and sizes are available on request.

TAC Rockford - Tel. 815 962-4500 - info@TACRockford.com - www.TACRockford.com