

Extensions

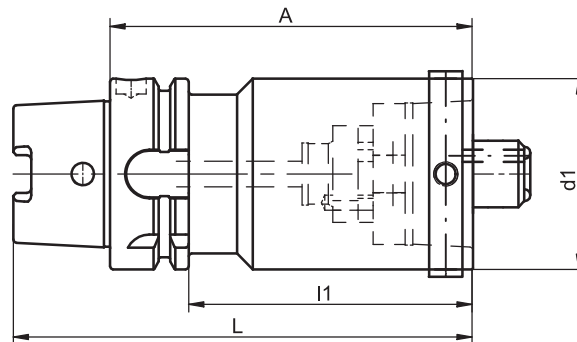

HSK-A	d1	A ± 0.05	Ref.no.	l1	L	kg
50	50	80	706.0001.321	54	105	1.2
63	63	80	706.0001.322	54	112	1.6
80	80	120	706.0002.323	94	160	3.5
100	100	140	706.0001.324	111	190	6.5

For coolant tubes see accessories page 4.8

For clamping cartridges see accessories page 4.15

For cover rings see accessories page 4.15

Use

For holding HSK tools according to ISO 12164-1/DIN 69 893-1 type A and C, d1 = nominal size HSK.

Design

Permissible concentricity deviation of hollow taper shank to inner taper 0.005 mm.

Standard Specification

Clamping cartridge and cover ring included.

Note

Other designs and sizes are available on request.