

Fine Boring Tools

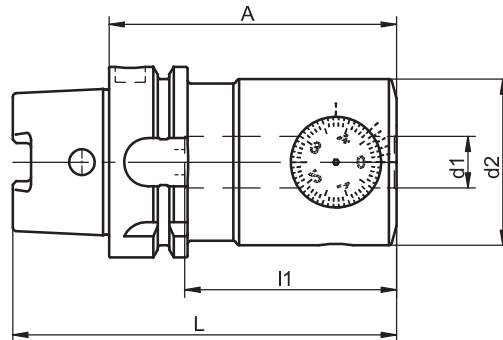

HSK-A	d1	A	Ref.no.	Boring range	d2	l1	L	kg
63	16	95	493.0011.322	9.75 - 88.1	55	70	127	1.5
100	16	100	493.0011.324	9.75 - 88.1	55	70	150	2.2

For coolant tubes see accessories page 4.8
 For boring bars see accessories page 4.16

Use

For boring bars with a shank diameter of 16 mm. For precision boring with close tolerances and high surface finish quality in the 9.75 to 88.1 mm diameter range.

Design

- Setting accuracy of 0.01 mm or 0.002 mm using a vernier scale.
- Micrometer spindle with a large scale for exact setting and easy reading.
- Minimum backlash.
- Variable overhang bar length positions for optimum stability.

- Internal coolant capability for chip clearance.

Standard Specification

Boring bars to be ordered separately.

TAC Rockford - Tel. 815 962-4500 - info@TACRockford.com - www.TACRockford.com