

Quick Change Tapping Chucks with Minimum Length Compensation

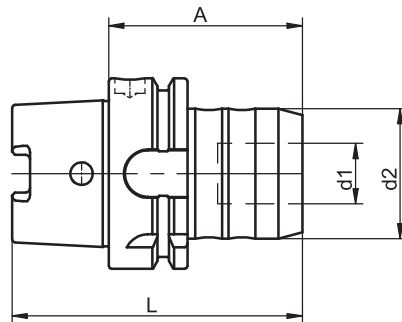

HSK-A	Thread	A	Ref.no.	Thread shaft	d1	d2	L	kg
40	M 3 - M12	69	440.0301.320	2 - 10	20	43	89	0.7
50	M 3 - M12	70	440.0301.321	2 - 10	20	43	95	0.9
63	M 3 - M12	64	440.0301.322	2 - 10	20	43	96	1.3
63	M 6 - M20	97	440.0302.322	2 - 16	32	60	129	2.0
100	M 3 - M12	70	440.0301.324	2 - 10	20	43	120	2.3
100	M 6 - M20	91	440.0302.324	2 - 16	32	60	141	2.8

For coolant tubes see accessories page 4.8

For i-tec®SLOTT quick change inserts see page 3.10

For ER quick change inserts see page 3.11

Use

For synchronous tapping on machining centres with length compensation on tension (1 mm) and compression (0.2 mm).

Note

Other designs and sizes are available on request.

TAC Rockford - Tel. 815 962-4500 - info@TACRockford.com - www.TACRockford.com