

# HSK-A hydraulic chucks with radial length setting

## Product information

- balancing quality: G6.3 / 15,000 rev./min
- robust, radially operated length setting
- clamping- $\varnothing$  for shank tolerance h6
- to DIN 69882-7

## Scope of delivery

- incl. clamping key Guhring no. 4912
- incl. hexagon key inserts for radial length setting
- order coolant delivery set, Guhring no. 4949, separately

Guhring no.

4296

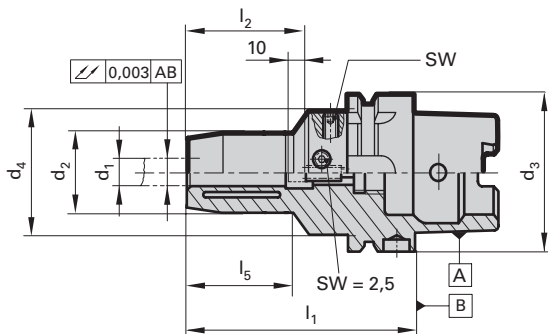

HSK-A d <sub>3</sub>	for clamping- $\varnothing$ d <sub>1</sub> h6 mm	d <sub>2</sub> mm	d <sub>4</sub> mm	l <sub>1</sub> mm	l <sub>2</sub> mm	l <sub>5</sub> mm	SW	kg	Code no.	Availability
50	6	26	40	80	37	35	5	0.8	6,050	•
50	8	28	40	80	37	36	5	0.8	8,050	•
50	10	30	40	85	41	41	5	0.9	10,050	•
50	12	32	40	90	46	47	5	0.9	12,050	•
63	6	26	50	80	37	33	5	1.1	6,063	•
63	8	28	50	80	37	33.5	5	1.1	8,063	•
63	10	30	50	85	41	39	5	1.1	10,063	•
63	12	32	50	90	46	44.5	5	1.2	12,063	•
63	14	34	50	90	46	46	5	1.2	14,063	•
63	16	38	50	95	49	51.5	5	1.3	16,063	•
63	18	40	50	95	49	52	5	1.3	18,063	•
63	20	42	50	100	51	58	5	1.4	20,063	•
63	25	50	63	120	57	51	5	2.3	25,063	•
63	32	60	63	125	61	59	5	2.3	32,063	•
80	6	26	50	85	37	35	5	1.5	6,080	◐
80	8	28	50	85	37	36	5	1.5	8,080	◐
80	10	30	50	90	41	38	5	1.5	10,080	◐
80	12	32	50	95	46	43	5	1.6	12,080	◐
80	14	34	50	95	46	43	5	1.6	14,080	◐
80	16	38	50	100	49	46	5	1.6	16,080	◐
80	18	40	50	100	49	48	5	1.8	18,080	◐
80	20	42	50	105	51	54	5	1.8	20,080	◐
80	25	50	63	115	57	51	5	2.6	25,080	◐
80	32	60	63	125	61	59	5	2.6	32,080	◐
100	6	26	63	85	37	33	5	2.5	6,100	•
100	8	28	63	85	37	33	5	2.7	8,100	•
100	10	30	63	90	41	36	5	2.8	10,100	•
100	12	32	63	95	46	40.5	5	2.8	12,100	•
100	14	34	63	95	46	42	5	2.7	14,100	•
100	16	38	63	100	49	47.5	5	2.9	16,100	•
100	18	40	63	100	49	48	5	2.8	18,100	•
100	20	42	63	105	51	54	5	3.2	20,100	•
100	25	50	63	115	57	51	5	3.4	25,100	•
100	32	60	63	120	61	59	5	3.4	32,100	•

Hydraulic chucks