

Measurement of the 30 degree clamping angle.

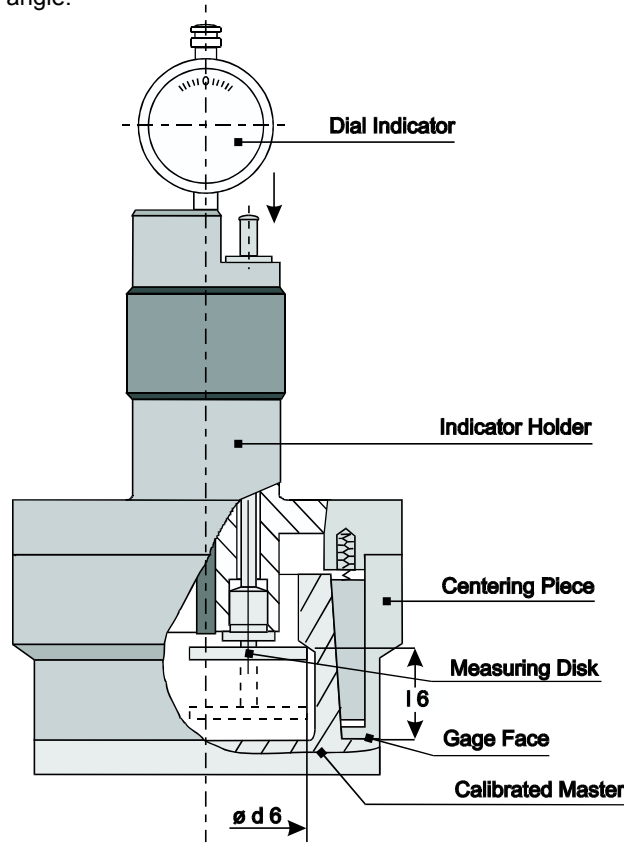

Tool taper per DIN 69 893 type A, C and E	Tool taper per per DIN 69 893 type B, D and F	Complete set in wooden case: dial indicator holder, dial indicator, centering piece, setting gage Ref.no.	l 6 JS 10	d 6
HSK 25	HSK 32	281.008	7.21	15
HSK 32	HSK 40	281.000	8.92	19
HSK 40	HSK 50	281.001	11.42	23
HSK 50	HSK 63	281.002	14.13	29
HSK 63	HSK 80	281.003	18.13	37
HSK 80	HSK 100	281.004	22.85	46
HSK 100	HSK 125	281.005	28.56	58
HSK 125	HSK 160	281.006	36.27	73
HSK 160	-	281.007	45.98	92

Description

Measuring gage with storage case: includes dial indicator holder, dial indicator, centering piece, and calibrated master.

Function

Using the calibrated master, the distance of the 30 degree clamping slope relative to l 2 is preset using the dial indicator holder. The tool taper to be measured is placed in the centering piece, allowing the variation of the taper to be measured.